

ARG259 UHC SERIES

ROLLING GRILLES



ARG259 'ULTRA HIGH CYCLE' ROLLING GRILLE

The ARG259 UHC 'Ultra High Cycle' Series is designed and tested for continuous duty environments. Parking Garage Closure is the most common application the ARG259 UHC is specified for.

The ARG259 Ultra High Cycle Rolling Grille has a 300,000 cycles and a two year warranty. The assembly coils around a springless barrel system with a safety inertia brake. The door system is powered by a continuous duty gearhead operator with a variable frequency drive for soft start and soft stop operation. The operator also comes with an upgraded concealed disc break. Horizontal curtain rods are made from high quality 6063 alloy aluminum extrusion. Curtain rods are spaced 2.5" vertically and allow ample ventilation. PVC spacer tubes are used between every link chain to help reduce both the overall weight of the curtain, and wear on hinging components. The aluminum extruded bottom bar is designed to accept a wireless pneumatic safety edge that comes standard with all high cycle grille designed. Monitored reflective photo-eyes also come as a standard feature.

The ARG259UHC is an excellent choice for a high traffic partition that demands performance and reliability.

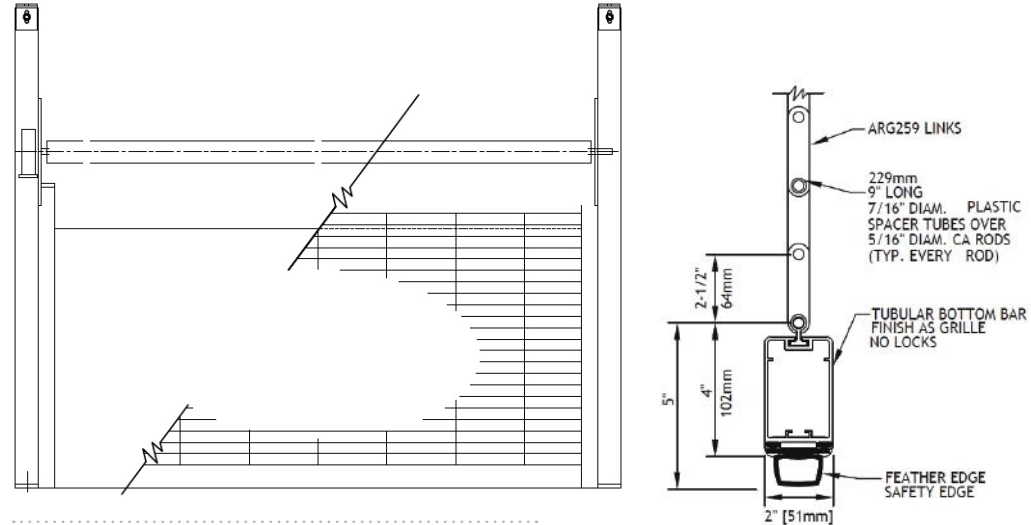

DIMENSIONS

Max. Width = 30'-0" | 9,144 mm

Max. Height = 20'-0" | 6,096 mm

Contact sales for larger opening sizes.

BRACKET PLATES

Constructed of 3/8" (9.5 mm) thick steel plate, prime painted gray for interior applications. Galvanized dip or powder coat finish for exterior applications.

FINISH

AA - Clear Anodized Aluminum Standard

CC - Customer Colour RAL or Colour Match

OPERATION CYCLES

300,000 cycles

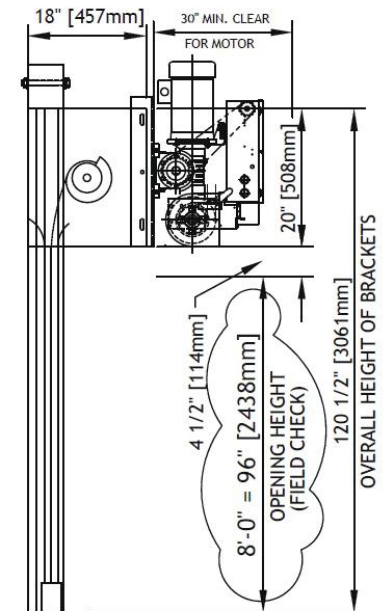
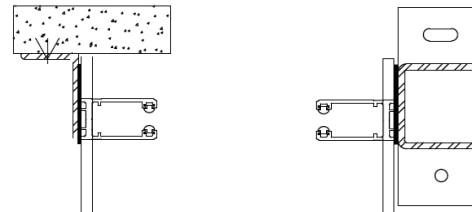

Measurements above may vary based on opening dimensions and configuration.